

Internal Freewheels FZ ...

with ball bearing properties

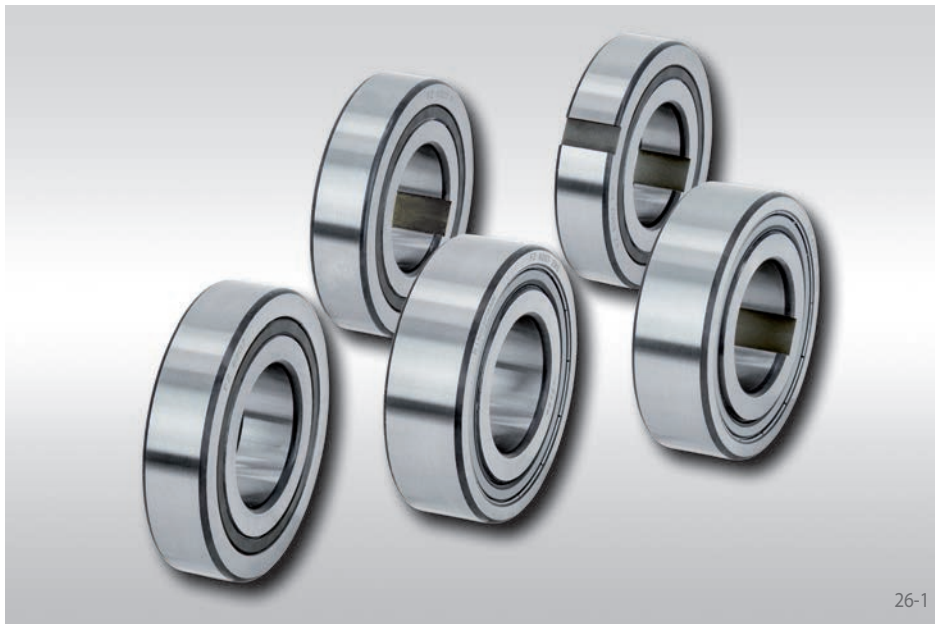

26-1

Application as

- ▶ Backstop
- ▶ Overrunning Clutch
- ▶ Indexing Freewheel

Features

Internal Freewheels FZ ... are sprag freewheels with bearing support and ball bearing properties. The freewheels are supplied grease-filled for normal operating conditions.

The freewheel is built into the customer housing. This makes compact, space-saving fitting solutions possible.

Maximum torques up to 619 lb-ft/840 Nm. The torque is transmitted on the inner ring and/or on the outer ring by press fit or keyway connection.

Bores up to 1.575 inch/40 mm.

The following series are available:

| Series | Torque transmission on | | | | 2RS-seals | Page |
|-------------|------------------------|--------------|------------|--------------|-----------|------|
| | outer ring | | inner ring | | | |
| | by keyway | by press fit | by keyway | by press fit | | |
| FZ | | ● | | ● | | 27 |
| FZ ... 2RS | | ● | | ● | ● | 28 |
| FZ ... P2RS | | ● | ● | ● | ● | 28 |
| FZ ... P | | ● | ● | ● | | 29 |
| FZ ... PP | ● | | ● | | | 29 |

Internal Freewheels FZ 6201 to FZ 6207, FZ 6201 P to FZ 6207 P and FZ 6202 PP to FZ 6207 PP have the same dimensions as the respective ball bearings of series 62. The freewheel sizes FZ 6208, FZ 6208 P and FZ 6208 PP as well as the series FZ ... 2RS and FZ ... P2RS have a different width B.

The series FZ ... 2RS and FZ ... P2RS have 2RS seals.

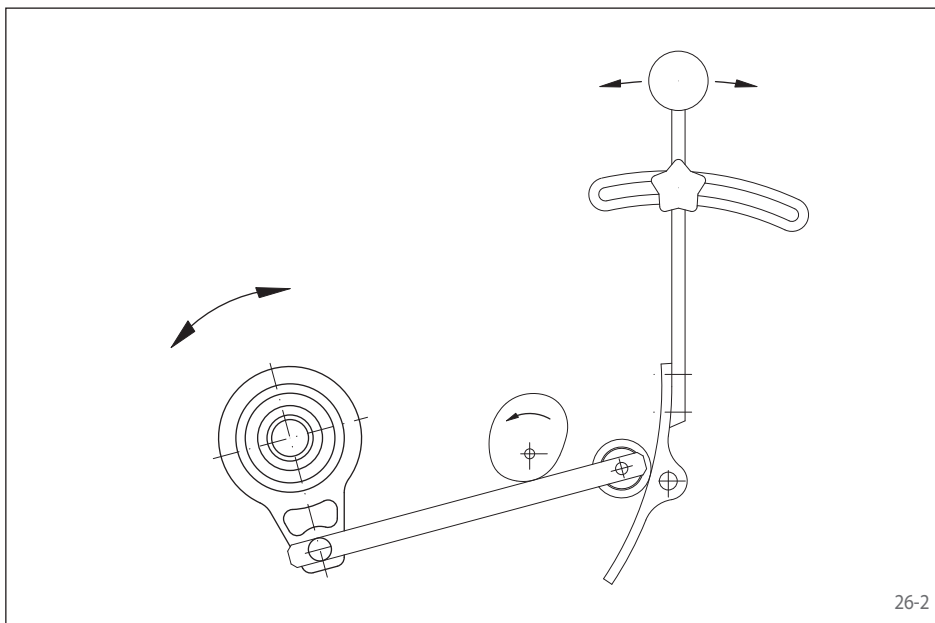

26-2

Application example

Two Internal Freewheels FZ 6206 as indexing freewheels in the drive of the metering roller of a seed spreader. The freewheels are built in an infinitely variable oil bath gearbox. Two cam disks that are set off by 180° are arranged on the gearbox shaft. By means of lever arms, these drive the outer rings of the two adjacent Internal Freewheels, which then gradually turn the metering shaft. The infinite speed settings of the gearbox's drive shaft are executed by means of the respective pivoting of the roller support plate, so that the lever arms can execute lifts of differing amounts.

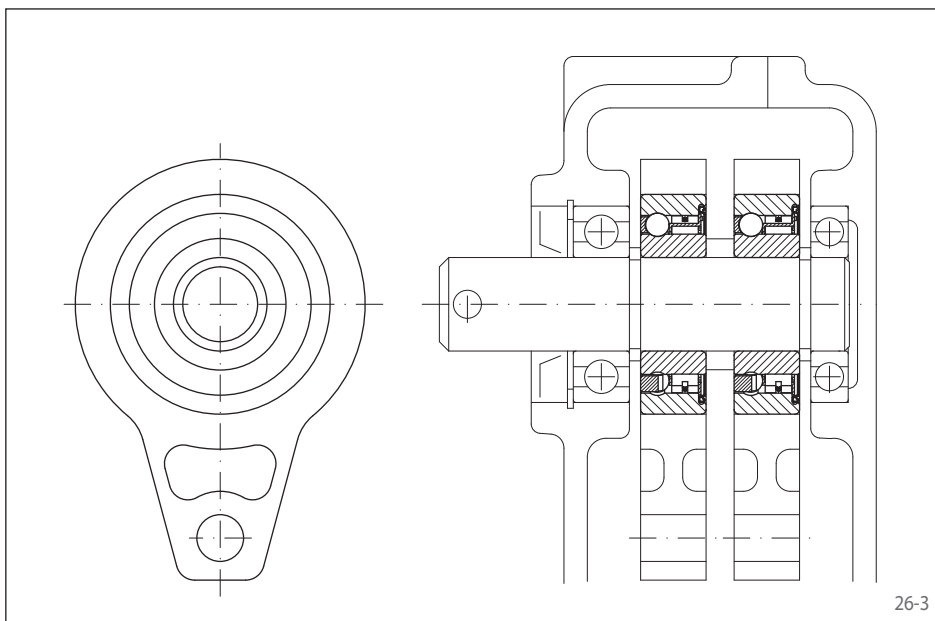

26-3

Internal Freewheels FZ

for press fit on the outer ring
with sprags, bearing supported

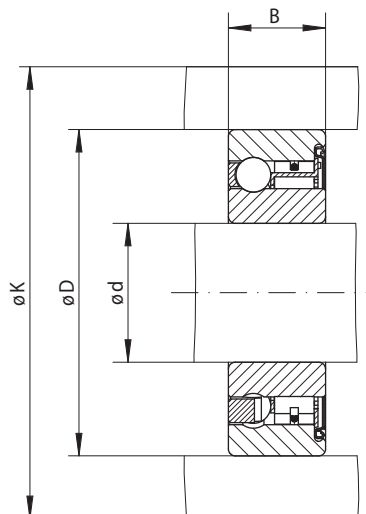

27-1

| Indexing Freewheel Overrunning Clutch Backstop | Standard type For universal use | Dimensions |
|--|------------------------------------|------------|
| | | |

| Freewheel Size | Maximum torque M_M | | Nominal torque M_N | | Maximum speed rpm | Load rating of bearing support | | | | Bore d | | B | | D | | K | | Weight | |
|----------------|----------------------|-----|----------------------|-----|----------------------|--------------------------------|------|--------------|------|--------|----|-------|-----|-------|----|-------|----|--------|------|
| | lb-ft | Nm | lb-ft | Nm | | dynamic C | N | static C_0 | N | inch | mm | inch | mm | inch | mm | inch | mm | lbs | kg |
| FZ 6201 | 13.28 | 18 | 6.64 | 9 | 10000 | 1155 | 5140 | 532 | 2370 | 0.472 | 12 | 0.394 | 10 | 1.260 | 32 | 1.535 | 39 | 0.09 | 0.04 |
| FZ 6202 | 30.98 | 42 | 15.49 | 21 | 9400 | 1160 | 5160 | 542 | 2410 | 0.591 | 15 | 0.433 | 11 | 1.378 | 35 | 1.654 | 42 | 0.14 | 0.06 |
| FZ 6203 | 47.20 | 64 | 23.60 | 32 | 8200 | 1270 | 5650 | 643 | 2860 | 0.669 | 17 | 0.472 | 12 | 1.575 | 40 | 2.008 | 51 | 0.18 | 0.08 |
| FZ 6204 | 129.80 | 176 | 64.90 | 88 | 6800 | 1549 | 6890 | 942 | 4190 | 0.787 | 20 | 0.551 | 14 | 1.850 | 47 | 2.283 | 58 | 0.26 | 0.12 |
| FZ 6205 | 147.50 | 200 | 73.75 | 100 | 5600 | 1625 | 7230 | 1048 | 4660 | 0.984 | 25 | 0.591 | 15 | 2.047 | 52 | 2.480 | 63 | 0.33 | 0.15 |
| FZ 6206 | 339.24 | 460 | 169.62 | 230 | 4000 | 1737 | 7730 | 1272 | 5660 | 1.181 | 30 | 0.630 | 16 | 2.441 | 62 | 2.874 | 73 | 0.55 | 0.25 |
| FZ 6207 | 486.72 | 660 | 243.36 | 330 | 3600 | 1836 | 8170 | 1490 | 6630 | 1.378 | 35 | 0.669 | 17 | 2.835 | 72 | 3.346 | 85 | 0.66 | 0.30 |
| FZ 6208 | 619.46 | 840 | 309.73 | 420 | 3000 | 2012 | 8950 | 1796 | 7990 | 1.575 | 40 | 0.866 | 22* | 3.150 | 80 | 3.710 | 94 | 1.10 | 0.50 |

See page 9 for determination of selection torque.

* The width of freewheel size FZ 6208 is different to the corresponding ball bearing 6208

Mounting

The torque is transmitted on the inner and outer ring by press fit. In order to transmit the torques specified in the table, the outer ring must be accommodated in a housing with an external diameter K. The housing is made of steel or grey cast iron in minimum quality GG-20. When using other housing materials or smaller external diameters, we urge you to contact us regarding the transmissible torque.

The tolerance of the housing bore D must be ISO N6 and the tolerance of the shaft must be ISO n6.

The permissible operating temperature of the freewheel is -40°F to +175°F.

Lubrication

The freewheels are supplied grease-filled for normal operating conditions.

However, the freewheels can also be connected to the customer's oil lubrication system; this is particularly recommended in the case of higher speeds.

Internal Freewheels FZ ... 2RS and FZ ... P2RS

for press fit on the outer ring
with sprags, bearing supported and sealed

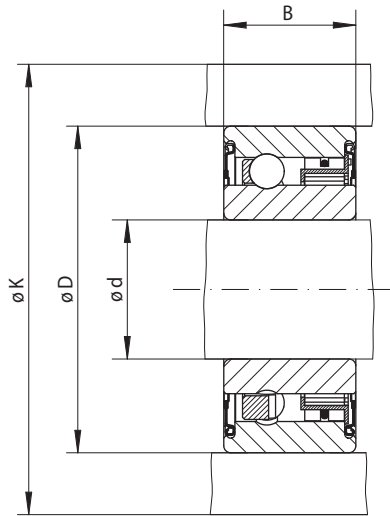

FZ ... 2RS

28-1

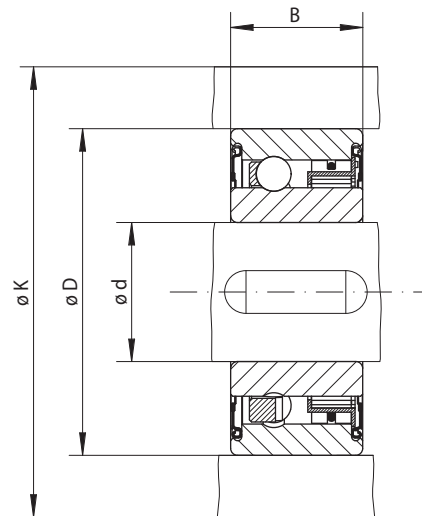

FZ ... P2RS

28-2

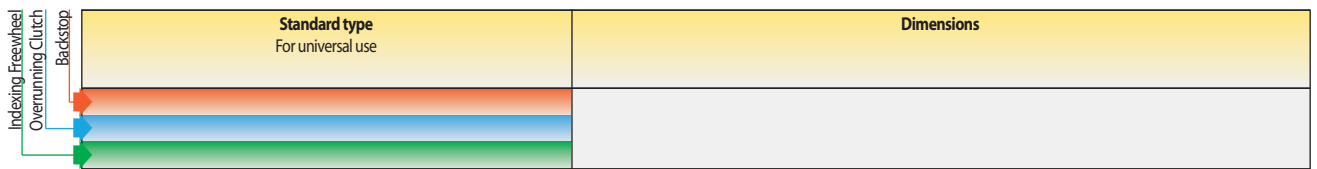

| Freewheel Size | | Maximum torque M_M | | Nominal torque M_N | | Maximum speed | Load rating of bearing support | | | | Bore d | | B* | | D | | K | | Weight | |
|-------------------|--------------------|----------------------|-----|----------------------|-----|---------------|--------------------------------|------|--------------|------|--------|----|-------|----|-------|----|-------|----|--------|------|
| Series FZ ... 2RS | Series FZ ... P2RS | lb-ft | Nm | lb-ft | Nm | rpm | dynamic C | | static C_0 | | inch | mm | inch | mm | inch | mm | inch | mm | lbs | kg |
| FZ 6201 2RS | FZ 6201 P2RS | 13.28 | 18 | 6.64 | 9 | 10000 | 1155 | 5140 | 532 | 2370 | 0.472 | 12 | 0.551 | 14 | 1.260 | 32 | 1.540 | 39 | 0.110 | 0.05 |
| FZ 6202 2RS | FZ 6202 P2RS | 30.98 | 42 | 15.49 | 21 | 8400 | 1160 | 5160 | 542 | 2410 | 0.591 | 15 | 0.630 | 16 | 1.378 | 35 | 1.654 | 42 | 0.154 | 0.07 |
| FZ 6203 2RS | FZ 6203 P2RS | 47.20 | 64 | 23.60 | 32 | 7350 | 1270 | 5650 | 643 | 2860 | 0.669 | 17 | 0.669 | 17 | 1.575 | 40 | 2.008 | 51 | 0.198 | 0.09 |
| FZ 6204 2RS | FZ 6204 P2RS | 129.80 | 176 | 64.90 | 88 | 6000 | 1549 | 6890 | 942 | 4190 | 0.787 | 20 | 0.748 | 19 | 1.850 | 47 | 2.283 | 58 | 0.330 | 0.15 |
| FZ 6205 2RS | FZ 6205 P2RS | 147.50 | 200 | 73.75 | 100 | 5200 | 1625 | 7230 | 1048 | 4660 | 0.984 | 25 | 0.787 | 20 | 2.047 | 52 | 2.480 | 63 | 0.396 | 0.18 |
| FZ 6206 2RS | FZ 6206 P2RS | 339.24 | 460 | 169.62 | 230 | 4200 | 1737 | 7730 | 1272 | 5660 | 1.181 | 30 | 0.827 | 21 | 2.441 | 62 | 2.874 | 73 | 0.594 | 0.27 |
| FZ 6207 2RS | FZ 6207 P2RS | 486.72 | 660 | 243.36 | 330 | 3600 | 1836 | 8170 | 1490 | 6630 | 1.378 | 35 | 0.866 | 22 | 2.835 | 72 | 3.346 | 85 | 0.881 | 0.40 |
| FZ 6208 2RS | FZ 6208 P2RS | 619.46 | 840 | 309.73 | 420 | 3000 | 2012 | 8950 | 1796 | 7990 | 1.575 | 40 | 1.063 | 27 | 3.150 | 80 | 3.710 | 94 | 1.322 | 0.60 |

See page 9 for determination of selection torque.

Keyway according to DIN 6885, page 3 • Tolerance of keyway width JS10.

* The width of freewheel size from FZ 6201 2RS to FZ 6208 2RS and FZ 6201 P2RS to FZ 6208 P2RS is different to the corresponding ball bearings of series 62.

Mounting

Series FZ ... 2RS:

The torque is transmitted on the inner and outer ring by press fit.

Series FZ ... P2RS:

The torque is transmitted on the inner ring by keyway connection and on the outer ring by press fit.

In order to transmit the torques specified in the table, the outer ring must be accommodated in a housing with an external diameter K. The housing is made of steel or grey cast iron in minimum quality GG-20. When using other housing materials or smaller external diameters, we urge you to contact us regarding the transmissible torque.

Lubrication

The freewheels are supplied grease-filled and with 2 RS seals.

The tolerance of the housing bore D must be ISO N6 and the tolerance of the shaft must be ISO k6.

The permissible operating temperature of the freewheel is -4 °F to +175 °F. Please contact the factory if the temperature is different than the given values.

Internal Freewheels FZ ... P and FZ ... PP

for press fit or for keyway connection on the outer ring
with sprags, bearing supported

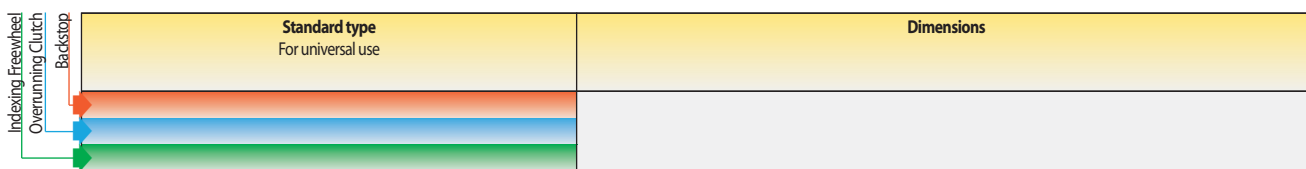
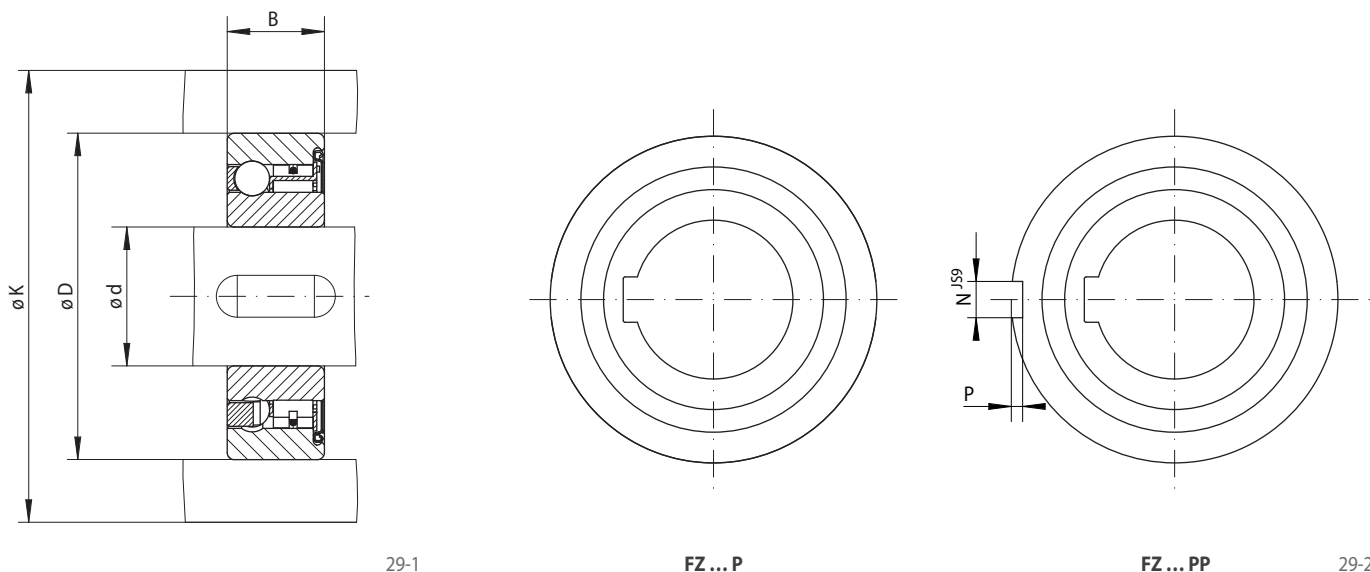

| Freewheel Size | | Maximum torque M_M | | Nominal torque M_N | | Maximum speed rpm | Load rating of bearing support | | | | Bore d | | B | | D | | K | | N | | P | | Weight | |
|-----------------|------------------|----------------------|-----|----------------------|-----|-------------------|--------------------------------|------|--------------|-------|--------|------|-------|------|-------|------|-------|------|------|------|------|------|--------|------|
| Series FZ ... P | Series FZ ... PP | lb-ft | Nm | lb-ft | Nm | | dynamic C | N | static C_0 | lb-ft | N | inch | mm | inch | mm | inch | mm | inch | mm | inch | mm | inch | mm | lbs |
| FZ 6201 P | | 13.28 | 18 | 6.64 | 9 | 10000 | 1155 | 5140 | 532 | 2370 | 0.472 | 12* | 0.394 | 10 | 1.260 | 32 | 1.535 | 39 | | | | | 0.09 | 0.04 |
| FZ 6202 P | FZ 6202 PP | 30.98 | 42 | 15.49 | 21 | 8400 | 1160 | 5160 | 542 | 2410 | 0.591 | 15* | 0.433 | 11 | 1.378 | 35 | 1.654 | 42 | 0.08 | 2 | 0.02 | 0.6 | 0.13 | 0.06 |
| FZ 6203 P | FZ 6203 PP | 47.20 | 64 | 23.60 | 32 | 7350 | 1270 | 5650 | 643 | 2860 | 0.669 | 17* | 0.472 | 12 | 1.575 | 40 | 2.008 | 51 | 0.08 | 2 | 0.04 | 1.0 | 0.15 | 0.07 |
| FZ 6204 P | FZ 6204 PP | 129.80 | 176 | 64.90 | 88 | 6000 | 1549 | 6890 | 942 | 4190 | 0.787 | 20* | 0.551 | 14 | 1.850 | 47 | 2.283 | 58 | 0.12 | 3 | 0.06 | 1.5 | 0.24 | 0.11 |
| FZ 6205 P | FZ 6205 PP | 147.50 | 200 | 73.75 | 100 | 5200 | 1625 | 7230 | 1048 | 4660 | 0.984 | 25* | 0.591 | 15 | 2.047 | 52 | 2.480 | 63 | 0.24 | 6 | 0.08 | 2.0 | 0.30 | 0.14 |
| FZ 6206 P | FZ 6206 PP | 339.24 | 460 | 169.62 | 230 | 4200 | 1737 | 7730 | 1272 | 5660 | 1.181 | 30* | 0.630 | 16 | 2.441 | 62 | 2.874 | 73 | 0.24 | 6 | 0.08 | 2.0 | 0.46 | 0.21 |
| FZ 6207 P | FZ 6207 PP | 486.72 | 660 | 243.36 | 330 | 3600 | 1836 | 8170 | 1490 | 6630 | 1.378 | 35* | 0.669 | 17 | 2.835 | 72 | 3.346 | 85 | 0.31 | 8 | 0.10 | 2.5 | 0.66 | 0.30 |
| FZ 6208 P | FZ 6208 PP | 619.46 | 840 | 309.73 | 420 | 3000 | 2012 | 8950 | 1796 | 7990 | 1.575 | 40 | 0.866 | 22** | 3.150 | 80 | 3.710 | 94 | 0.39 | 10 | 0.12 | 3.0 | 1.10 | 0.50 |

See page 9 for determination of selection torque.

Keyway according to DIN 6885, page 1 • Tolerance of keyway width JS10.

* Keyway according to DIN 6885, page 3 • Tolerance of keyway width JS10.

** The width of freewheel size FZ 6208 P and FZ 6208 PP is different to the corresponding ball bearing 6208.

Mounting

Series FZ ... P:

The torque is transmitted on the inner ring by keyway connection and on the outer ring by press fit.

Series FZ ... PP:

The torque is transmitted on the inner and on the outer ring by keyway connection.

In order to transmit the torques specified in the table, the outer ring must be accommodated in a housing with an external diameter K. The housing is made of steel or grey cast iron in minimum quality GG-20. When using other housing materials or smaller external diameters, we urge you to contact us regarding the transmissible torque.

Lubrication

The freewheels are supplied grease-filled.

The tolerance of the housing bore D must be ISO H6 and the tolerance of the shaft must be ISO h6.

The permissible operating temperature of the freewheel is -40 °F to +175 °F. Please contact the factory if the temperature is different than the given values.