

Housing Freewheels FH

for stationary arrangement in multimotor drives

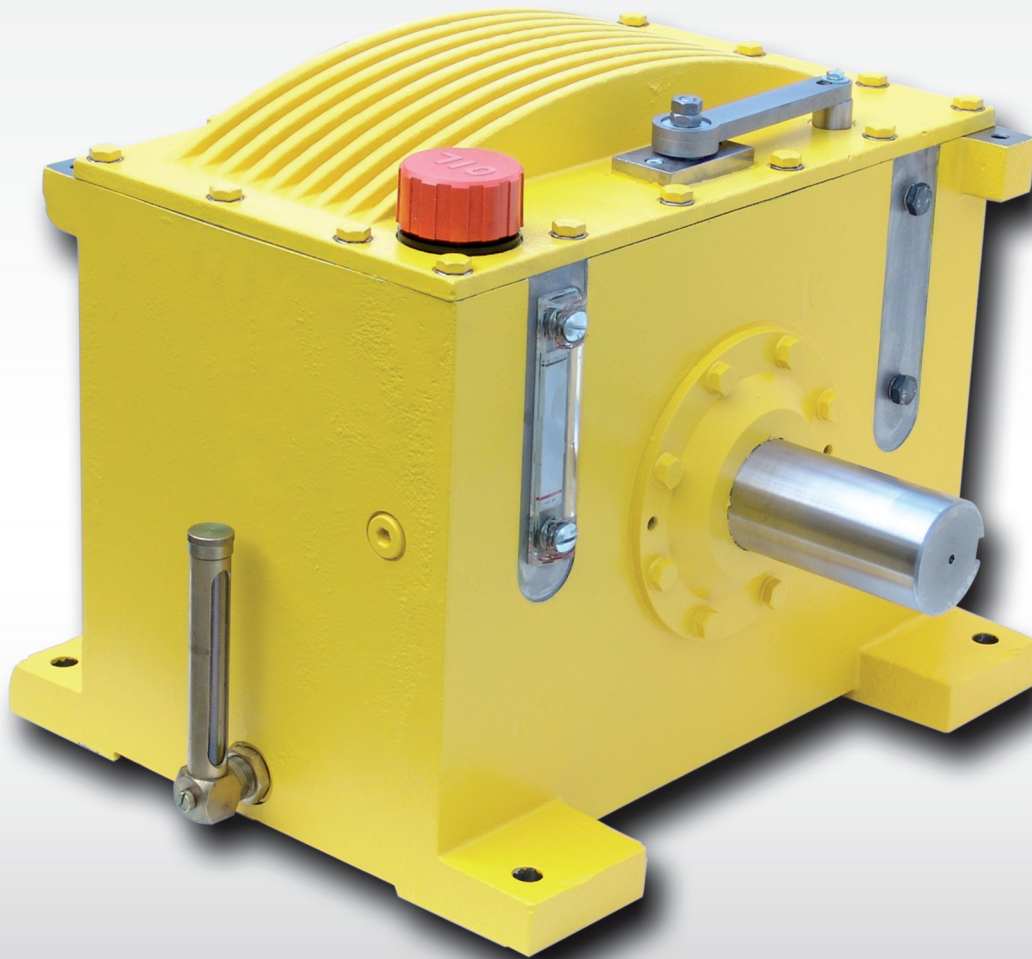

Quality Products • Competitive Price • Quick Delivery

Housing Freewheels FH

for stationary arrangement in multimotor drives with hydrodynamic roller lift-off for extended service life

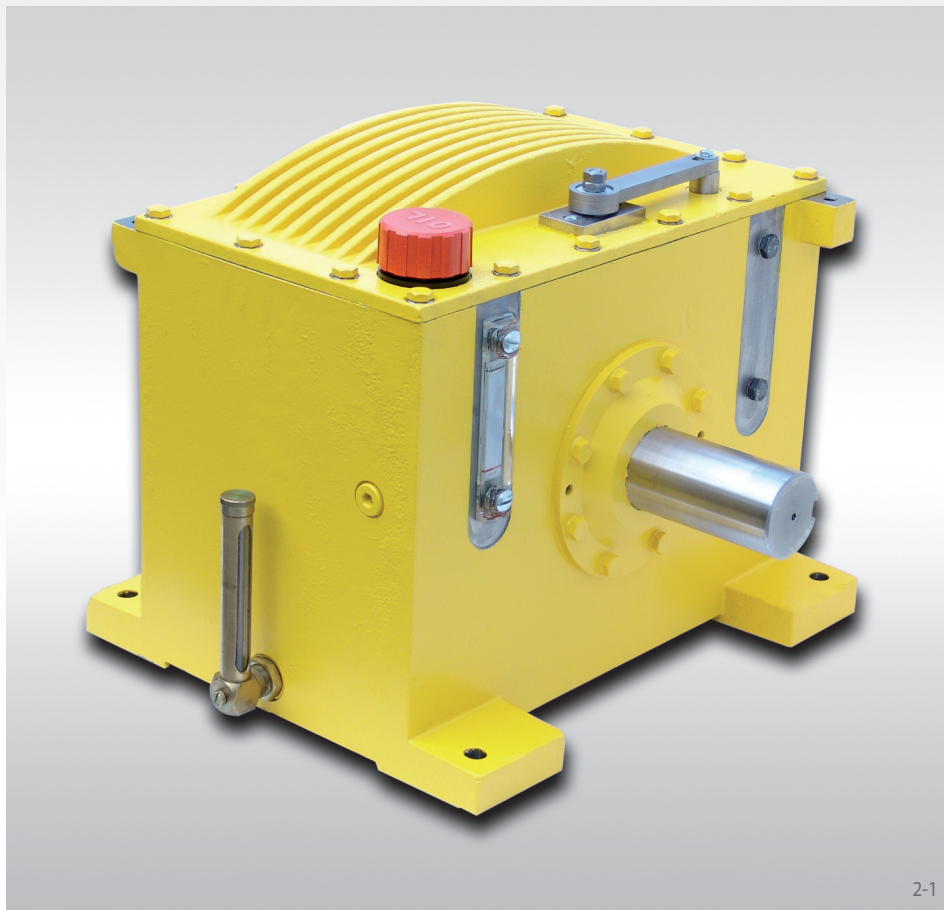

2-1

Application as

Overrunning Clutch

at high speeds, which are the same or similar in freewheeling operation and in driving operation.

Features

Housing Freewheels FH with hydrodynamic roller lift-off are typically used in cases where an assembly can be driven from two or more motors or turbines at the same or similar high speed. They allow a continuous plant operation in the event that one of the energy sources or a drive line fails as well as energy saving in the case of partial load operation.

The Housing Freewheels FH are completely enclosed freewheels for stationary arrangement with input and output shaft.

Advantages

- Nominal torques up to 30 000 lb-ft
- Shaft diameter up to 5.078 inch
- Wear-free operation
- Low noise
- Low power dissipation
- Integrated oil filtration system
- Integrated locking brake
- Oil change without down time

Hydrodynamic roller lift-off

Housing Freewheels FH are equipped with hydrodynamic roller lift-off. The hydrodynamic roller lift-off is the ideal solution for overrunning

clutches at high speeds, not only in freewheeling operation, but also in the driving operation, as can occur, for example, in multimotor drives.

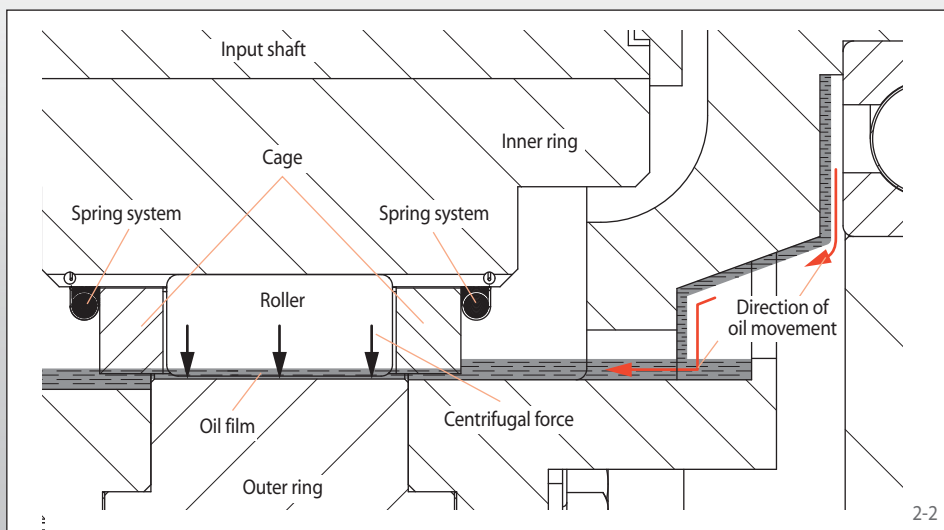

In the case of hydrodynamic roller lift-off, the lifting force is generated by an oil film applied during freewheeling operation by centrifugal force exerted on the outer ring race. This provides for practically wear-free freewheeling operation. The speed differential between the inner and outer rings is the decisive factor affecting the lift-off function. If the speed differential decreases, the lift-off force also decreases. Before achieving synchronous running, the clamping rollers guided in a cage are positioned with the aid of the central spring system against the outer ring race and are then ready to lock. This guarantees immediate torque transfer once the synchronous speed has been reached. The hydrodynamic roller lift-off enables a virtually wear-free freewheeling operation.

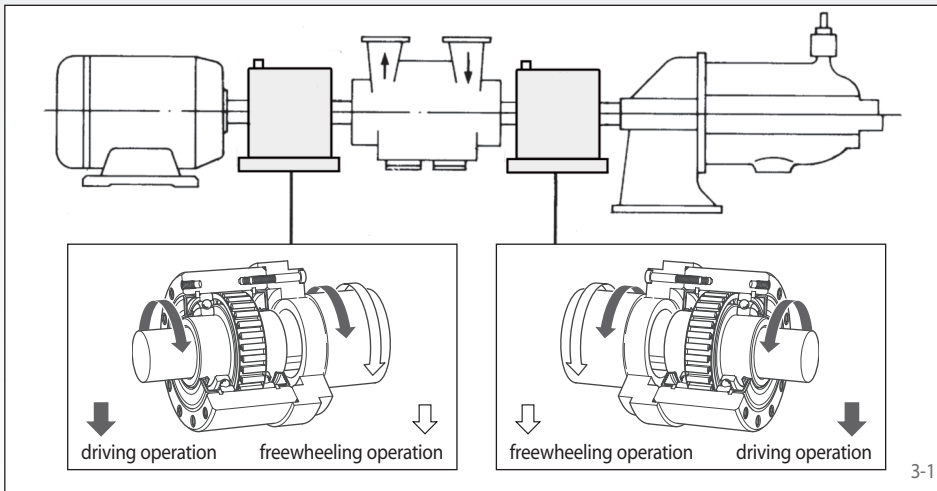

Areas of application

Housing Freewheels as automatic clutches in multimotor drives fulfil here an important function. They disengage a drive automatically as soon as it no longer provides power to the working machine. The Housing Freewheels do not require any external operating equipment.

Typical applications for multimotor drives are:

- Generators
- Pumps
- Ventilators
- Fans
- Uninterrupted power supply

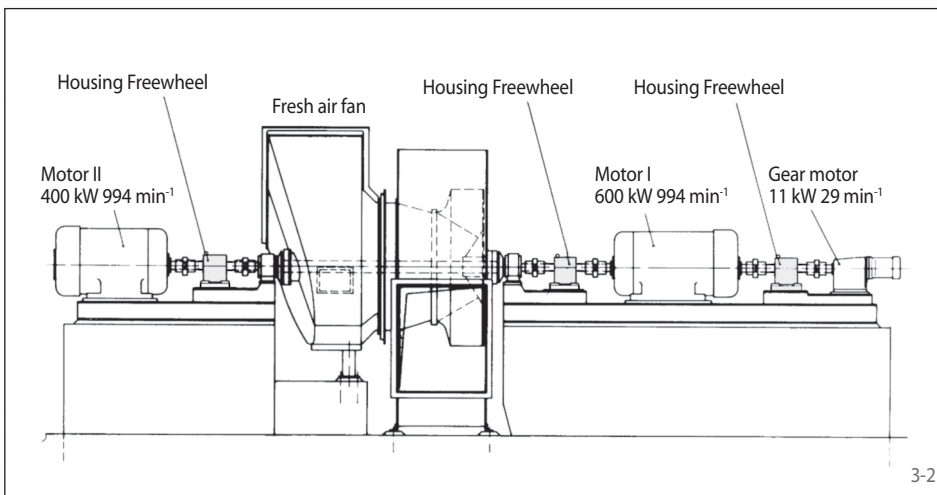

Application example

Three Housing Freewheels in the multimotor drive of a fresh air fan. The fan is driven by one or two electric motors. An additional auxiliary drive serves to slowly turn the fan for the purposes of inspection work or for an even cooling down after shut down. The Housing Freewheels automatically engage the respective working electric motor to the fan.

Selection torque for Housing Freewheels FH

In many cases where overrunning clutches are being used, dynamic processes occur that cause high peak torques. In the case of overrunning clutches, the torques that occur during start up must be observed. The peak torques when starting up can, in the case of asynchronous motors - especially when accelerating large masses and when using elastic couplings - significantly exceed the torque calculated from the motor pullover torque. The conditions for internal combustion engines are similar. Even in normal operation, on account of their degree of irregularity, peak torques can occur that are way in excess of the nominal torque.

The prior determination of the maximum occurring torque is carried out most safely by using a rotational vibration analysis of the entire system. This, however, requires a knowledge of the rotating masses, the rota-

tional rigidity and all of the excitation moments that occur on the system. In many cases, a vibrational calculation is too time consuming or you may not have all the necessary data in the configuration phase available. In this case, the selection torque M_A of the overrunning clutch should be determined as follows:

$$M_A = K \cdot M_L$$

In this equation:

M_A = Selection torque of the freewheel

K = Operating factor

M_L = Load torque for constant rotating freewheel:

$$= 9550 \cdot P_0 / n_{FR}$$

P_0 = Nominal power of motor [kW]

n_{FR} = Speed of the freewheel in driving operation [min⁻¹]

After calculating M_A the freewheel size must be selected in accordance with the catalogue tables in such a way that in all cases this applies:

$$M_N \geq M_A$$

M_N = Nominal torque of the Housing Freewheel FH in accordance with the table values [Nm]

The operating factor K depends on the properties of the driver and the machine. The general rules of mechanical engineering apply here. We recommend using an operating factor K of at least 1,5. We will be pleased to check your selection.

Interchange Chart

For Housing Freewheels

RINGSPANN®

Manufacturer	RINGSPANN	Marland	Stieber	Tsubaki	Hilliard
Type Nominal torque lb-ft Max. speed min ⁻¹		FKhG 24 ATR 811 2,400			EO-0900 896 3,600
Type Nominal torque lb-ft Max. speed min ⁻¹	FH 1000 1,000 5,600		1M 1,000 5,600		OB 100-ON 1,195 1,800
Type Nominal torque lb-ft Max. speed min ⁻¹		FKhG 28 ATR 1,660 2,400		50-G3 1,586 3,400	EO-1600 1,593 3,000
Type Nominal torque lb-ft Max. speed min ⁻¹	FH 2000 2,000 4,200	FKhG 94 ATR 2,508 1,800	2M 2,000 4,200	60-G3 2,581 2,900	TB 40-120 2,316 1,800
Type Nominal torque lb-ft Max. speed min ⁻¹		FKhG 106 ATR 3,098 1,800			EO-3200 3,186 2,800
Type Nominal torque lb-ft Max. speed min ⁻¹	FH 4000 4,000 3,600		4M 4,000 3,600	70-G3 4,241 2,600	TB 60-140 4,337 1,500
Type Nominal torque lb-ft Max. speed min ⁻¹		FKhG 148 ATR 5,163 1,500			
Type Nominal torque lb-ft Max. speed min ⁻¹	FH 8000 8,000 3,000		8M 8,000 3,000		
Type Nominal torque lb-ft Max. speed min ⁻¹		FKhG 2.53 ATR 10,326 1,500		90-G4 10,695 2,000	EO-110C 10,953 2,000
Type Nominal torque lb-ft Max. speed min ⁻¹	FH 12000 12,000 2,500		12M 12,000 2,500		TB 70-160 12,981 1,500
Type Nominal torque lb-ft Max. speed min ⁻¹	FH 18000 18,000 2,300		18M 18,000 2,300		TB 80-180 18,070 1,200
Type Nominal torque lb-ft Max. speed min ⁻¹	FH 30000 30,000 2,000		30M 30,000 2,000		