

Brake Caliper DH 035 FPM

spring activated – pneumatically released

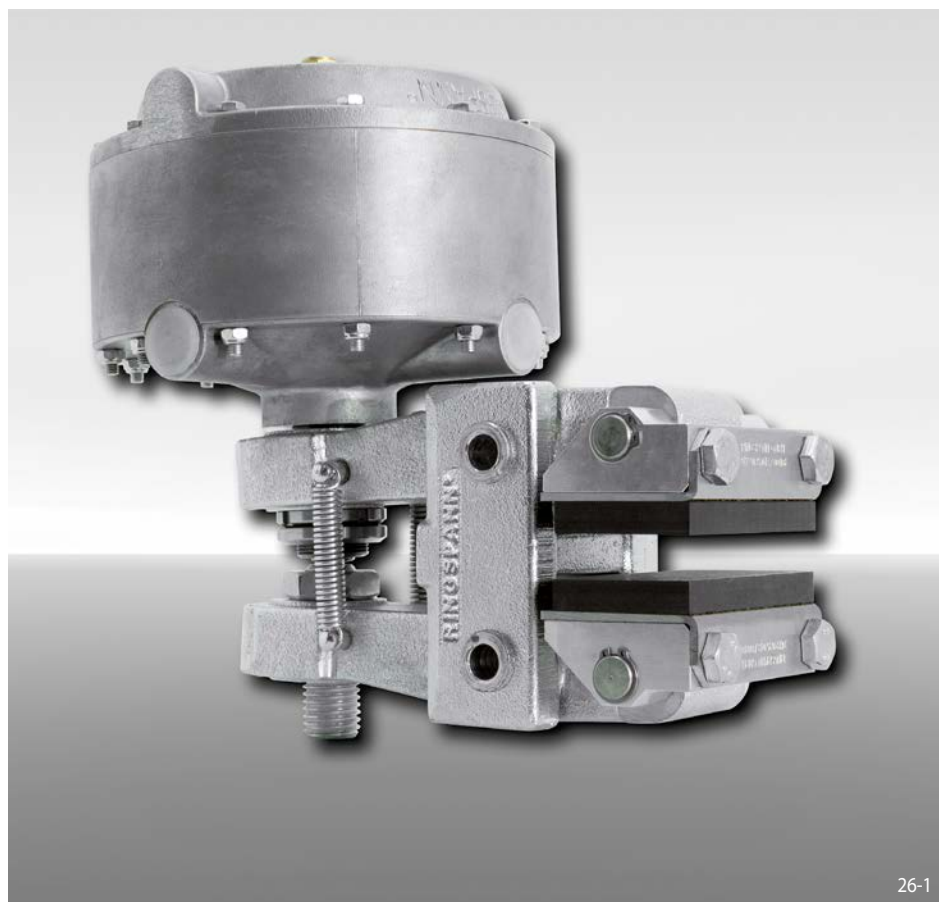

Features	Code
Brake Caliper	D
Mounting to the machine at right angles to the brake disc	H
Frame size 035	035
Spring activated	F
Pneumatically released	P
Manual adjustment to accommodate friction block wear	M
Thrusters 025, 035, 045, 102, 111 or 122 are available	025 to 122
Thruster mounted right or left available	R L
Thickness of brake disc 12,5 mm, 25 mm, 30 mm or 40 mm	12 to 40

Example for ordering

Brake Caliper DH 035 FPM, thruster 111, thruster mounted right, thickness of brake disc 12,5 mm:

Technical Data

DH 035 FPM - 111 R - 12

	Brake Caliper DH 035 FPM					
	with thruster 025	with thruster 035	with thruster 045	with thruster 102	with thruster 111	with thruster 122
Brake disc diameter	Braking torque	Braking torque	Braking torque	Braking torque	Braking torque	Braking torque
mm	Nm	Nm	Nm	Nm	Nm	Nm
300	430	640	900	820	1450	1850
355	530	790	1100	1000	1750	2250
430	670	990	1400	1300	2250	2850
520	840	1250	1750	1600	2800	3550
630	1050	1550	2150	2000	3450	4400
710	1200	1750	2450	2250	3950	5000
800	1350	2000	2800	2600	4500	5750
Clamping force	4600 N	6800 N	9600 N	8800 N	15300 N	19500 N
Air pressure	min. 5 bar max. 8 bar	min. 4,2 bar max. 8 bar	min. 5 bar max. 8 bar	min. 3 bar max. 8 bar	min. 5 bar max. 8 bar	min. 6,5 bar max. 8 bar
Air volume per activation	max. 120 cm ³	max. 185 cm ³	max. 185 cm ³	max. 540 cm ³	max. 540 cm ³	max. 540 cm ³
Weight	10,6 kg	13,0 kg	13,0 kg	14,2 kg	14,2 kg	14,2 kg

The braking torques shown in the table are based on a theoretical friction coefficient of 0,4.

Brake Caliper DH 035 FPM

spring activated – pneumatically released

