

Brake Caliper HW 180 HFA

hydraulically activated – spring released

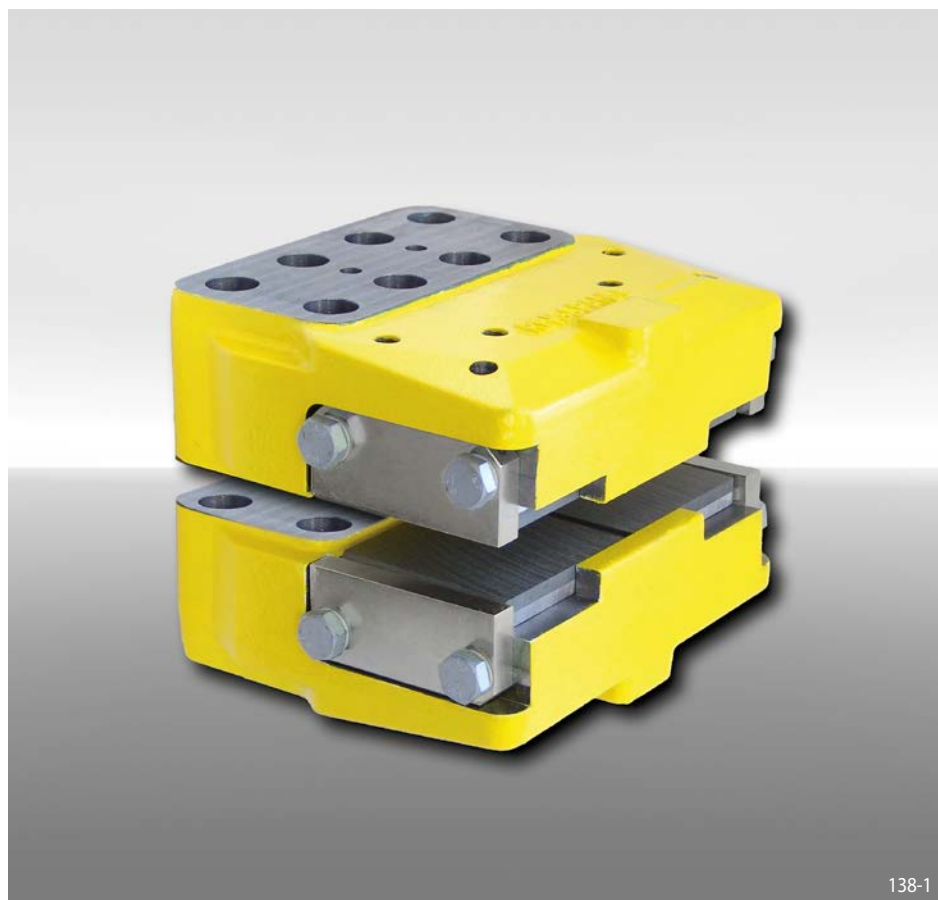

Features	Code
Brake Caliper	H
Standard	W
Frame size 180	180
Hydraulically activated	H
Spring released	F
Automatic adjustment to accommodate friction block wear	A
Max. clamping force 200 kN	200

Example for ordering

Brake Caliper HW 180 HFA, max. clamping force 200 kN:

HW 180 HFA - 200

Technical Data

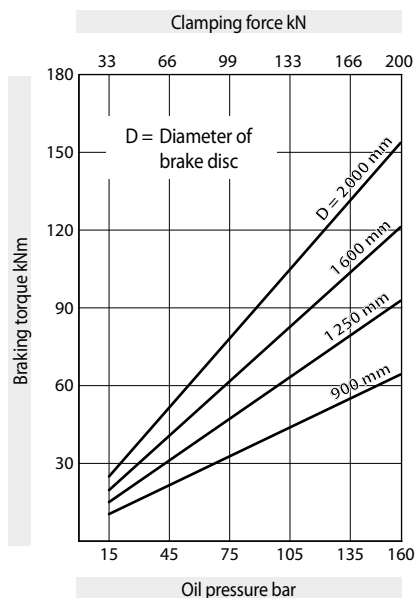

The braking torques shown in the diagram are based on a theoretical friction coefficient of 0,4.

Oil pressure: min. 15 bar
max. 160 bar

Oil volume: max. 190 cm³

Weight: ca. 65 kg

Other features

- High safety against leakage
- Painted with surface coating class C4-L according to ISO 12944
- The thickness of the customer connecting part results from the thickness of the brake disc W

Accessories

- Optional painting with surface coating class C4-H or C5M-H (offshore) according to ISO 12944

Brake Caliper HW 180 HFA

hydraulically activated – spring released

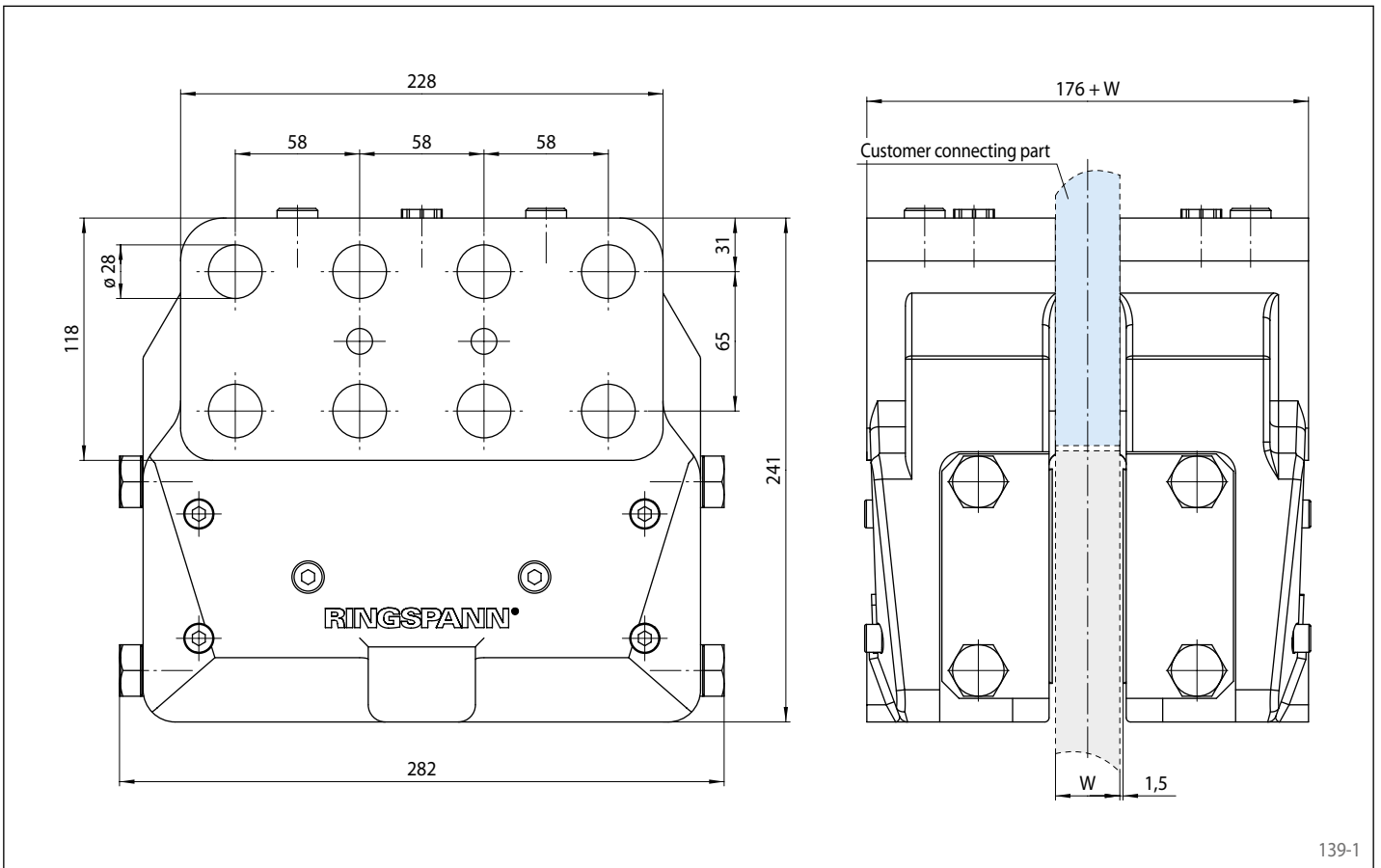

139-1

Mounting

