

Brake Calipers EV 018 EFM and EH 018 EFM

electromagnetically activated – spring released

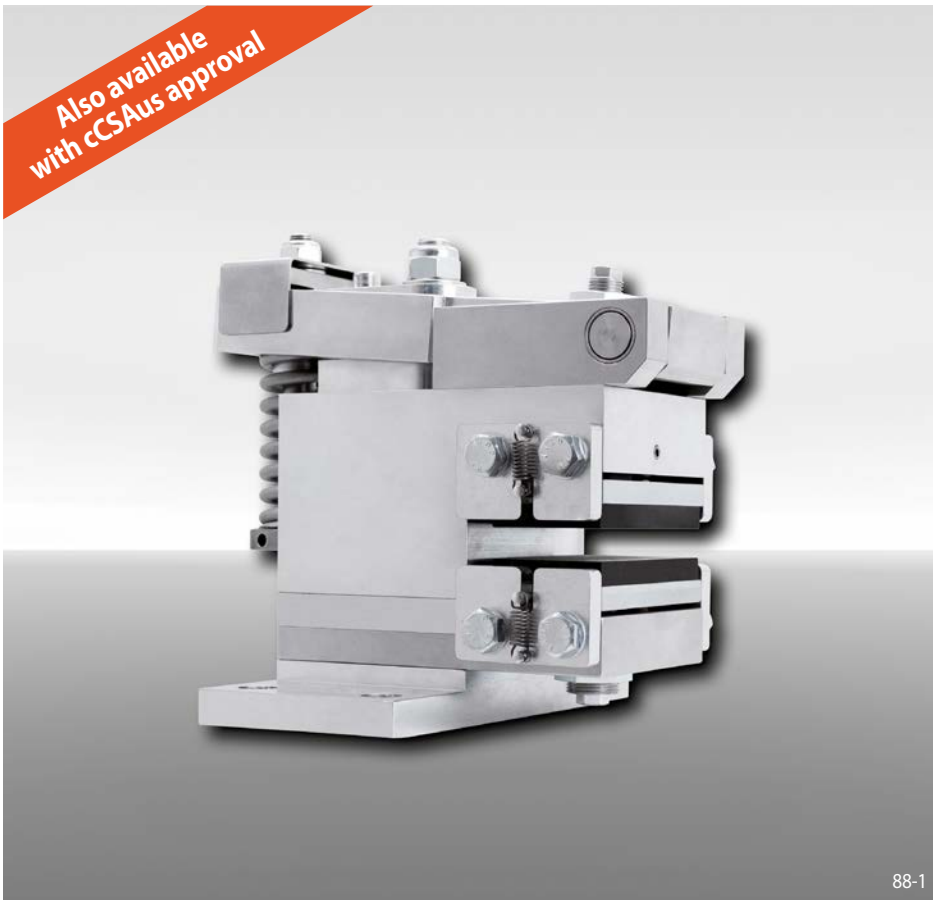

Features

Features	Code
Brake Caliper with electromagnet	E
Mounting to the machine parallel or at right angles to the brake disc	V H
Frame size 018	018
Electromagnetically activated	E
Spring released	F
Manual adjustment to accommodate friction block wear	M
Supply voltage 220 to 240 VAC	240
Supply voltage 380 to 480 VAC	480
Electromagnet mounted in central position	M
Thickness of brake disc 8 ... 15 mm	12
or 16 ... 20 mm	20

Example for ordering

Brake Caliper EV 018 EFM, supply voltage 400 VAC, electromagnet mounted in central position, thickness of brake disc 15 mm:

EV 018 EFM - 480 M - 12

Advantages

The brake caliper EV 018 EFM or EH 018 EFM is a very compact and high efficient disc brake with very low power consumption. Its floating bearing compensates small misalignments of the brake disc. The separate electronic module (included) reduces the power consumption in closed position automatically.

Options

- Available with cCSAus approval
- Inductive proximity switch: "Brake released"-, "Brake closed"-status and/or "Friction block wear adjustment necessary"

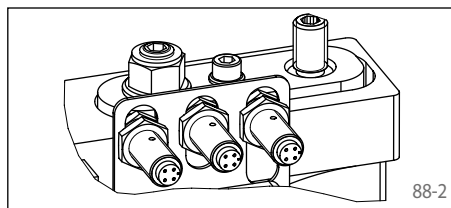

Electronic module

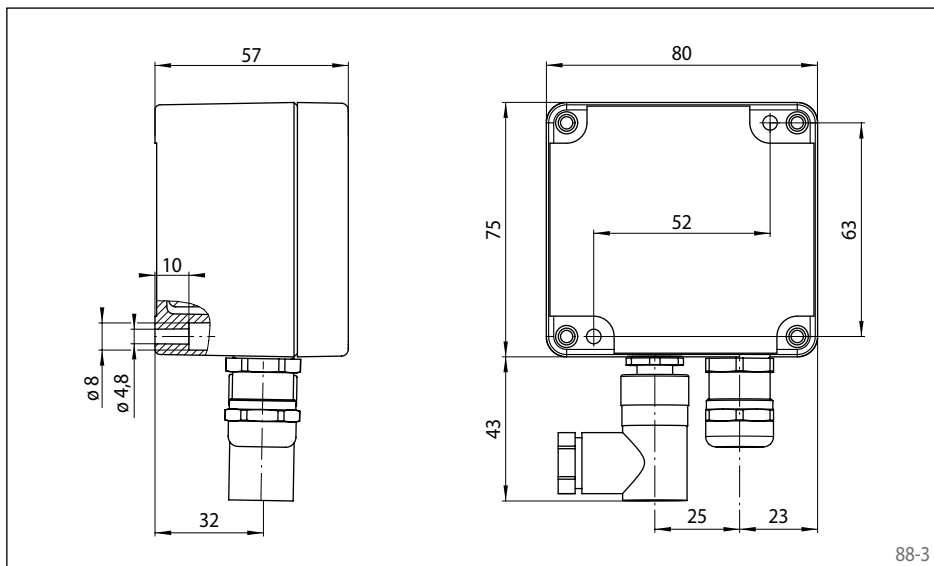

Technical Data

	Brake Calipers EV 018 EFM and EH 018 EFM with supply voltage	
	220 to 240 VAC	380 to 480 VAC
Brake disc diameter mm	Braking torque Nm	Braking torque Nm
125	100	
150	130	
200	200	
250	260	
300	320	
355	400	
Clamping force	3 200 N	
Response time*	250 ms	
Clamping force or braking torque adjustable	50 - 100%	
Power consumption in closed position	24 W	32 W (100% duty factor)
Power when closing the brake (< 1 s)	800 W	1 200 W
Fuse rating	10 A, Type "B"	
Max. number of actuation	360/h permanent activations at 20° C ambient temperature	
Actuation frequency**	at least 8 seconds between 2 activations	
Weight	6,5 kg	

The braking torques shown in the diagram are based on a theoretical friction coefficient of 0,4.

* The response time is the duration from switching off the power supply to reaching 80% of the maximum clamping force (at Ta = 20 °C, setting: 100%).

** Shorter actuation frequency on request

Brake Calipers EV 018 EFM and EH 018 EFM

electromagnetically activated – spring released

Brake Caliper EV 018 EFM

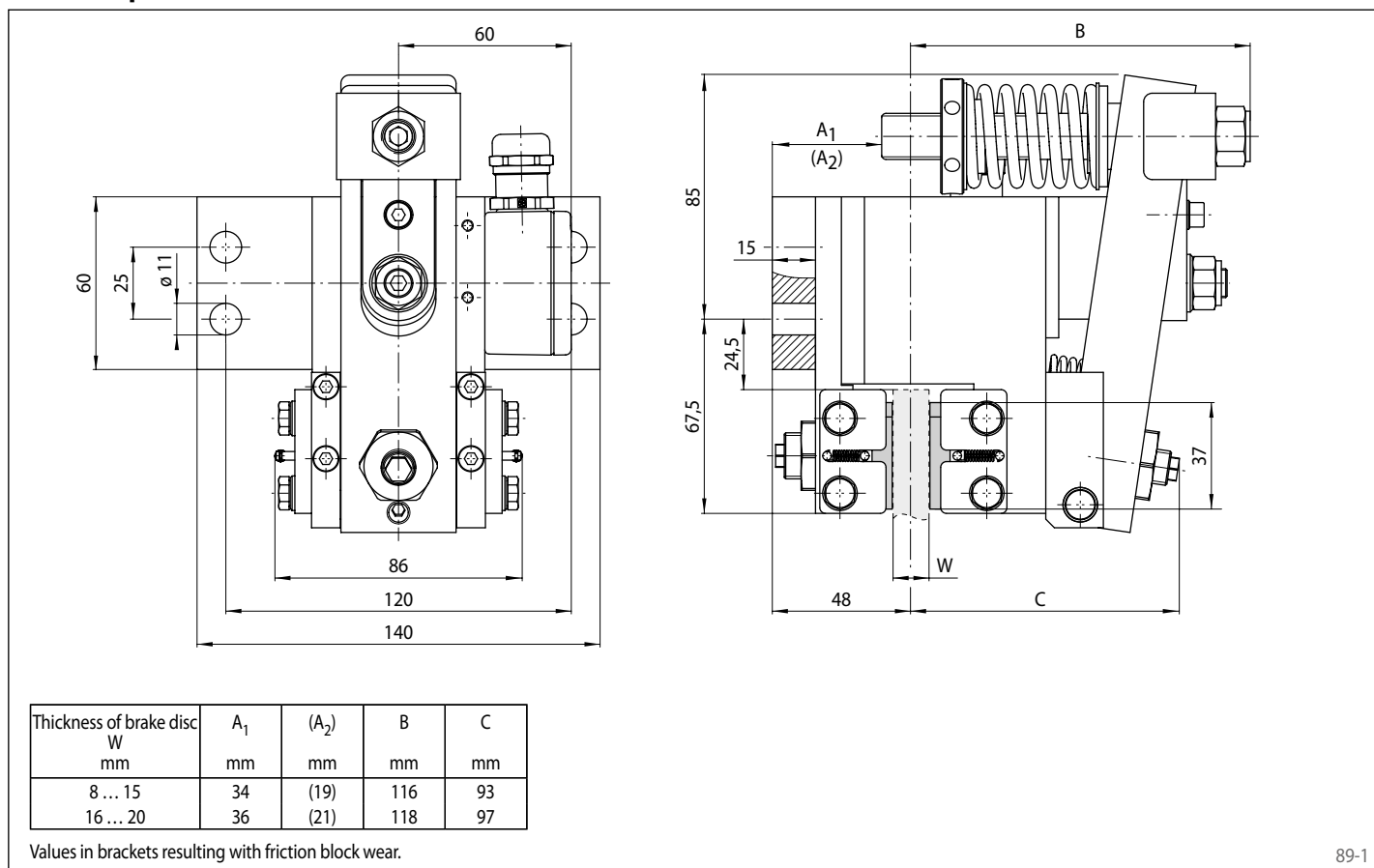

89-1

Brake Caliper EH 018 EFM

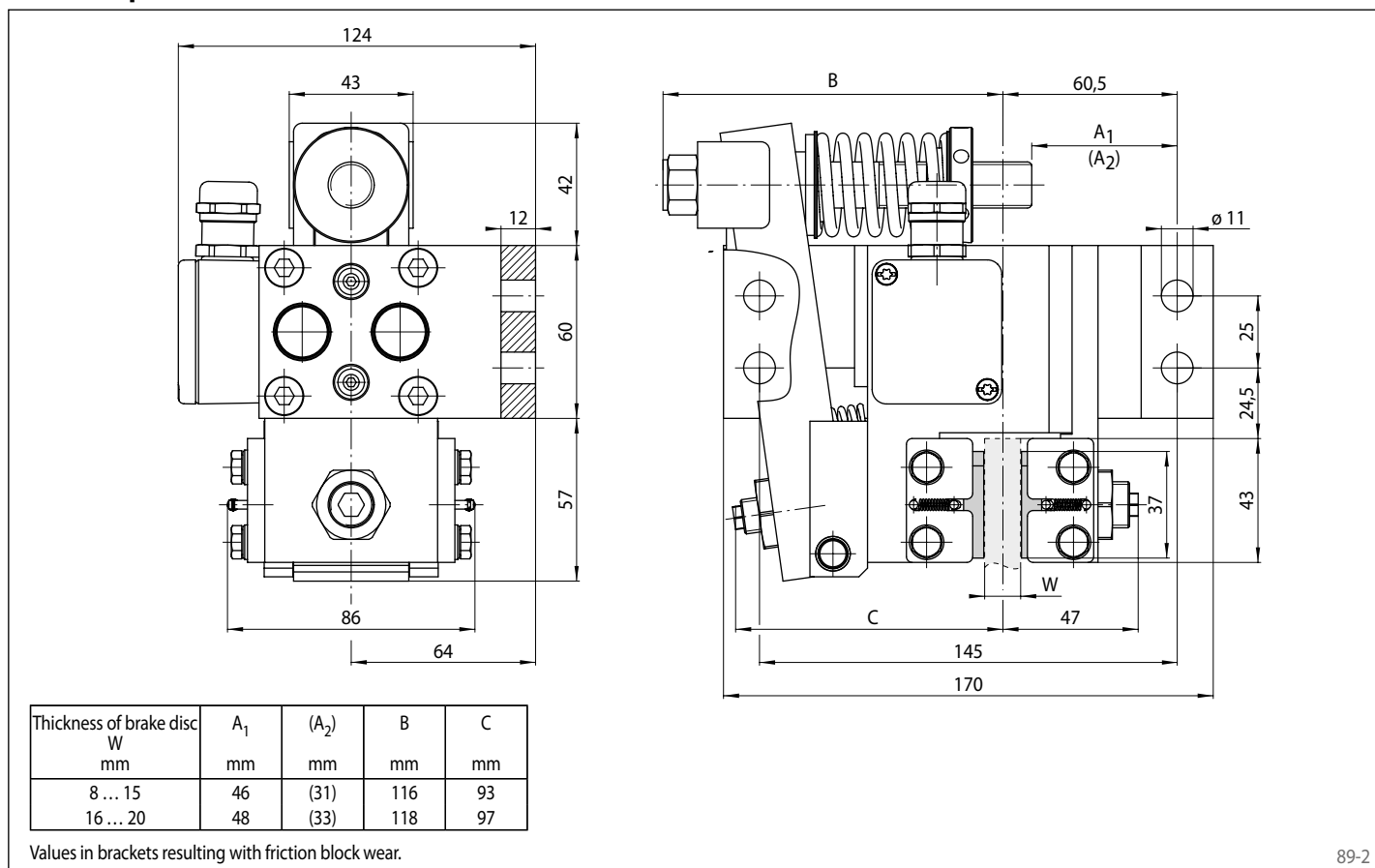

89-2